

Aluminium column SAL-4,5/D60

diameter 114 mm at the base plate

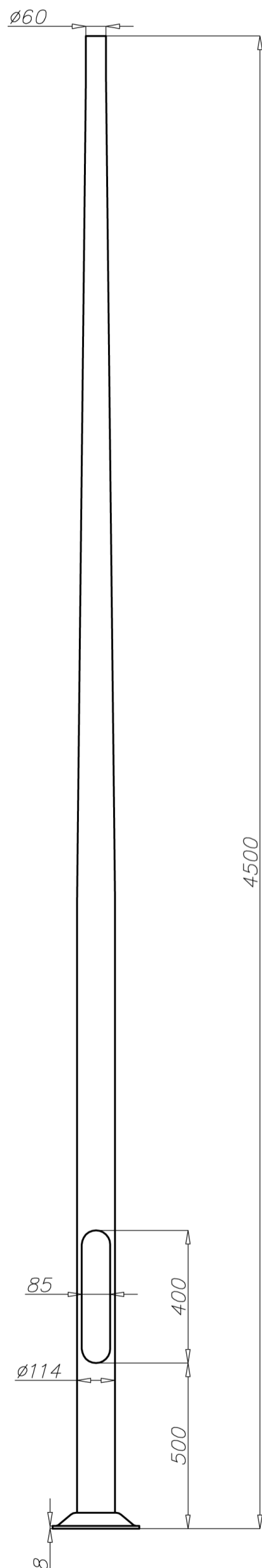

Technical data

Aluminium Column	SAL-4,5/D60
Product code	42116
Column height H [m]	4,5
Wall thickness [mm]	3
Net weight [kg]	13,3
Volume [m ³]	0,13
Post top column	luminaires with Ø60 spigot entry with weight and windage not exceeding data in resistance calculations
Compatible extension arms	according to resistance calculations
Concrete footing / reinforcement basket	B-51 / Z-51
Concrete footing code/reinforcement basket code	311151 / 311251
Hot galvanized nut set /Hot galvanized ripable nut set	4008 / 4009

Resistance calculations

SAL-4,5/D60 code 42116		acceptable windage of single luminaire [m ²] for C _x =0,7			
		Vref. = 22 m/s	Vref. = 24 m/s	Vref. = 26 m/s	Vref. = 28 m/s
extension arm type	acceptable weight of single luminaire	I zone, II location category	I and III zone, II location category to 450 m AMSL	II zone, II location category	III zone, II location category to 755 m AMSL
WA-01	10	0,39	0,31	0,19	0,16
WA-1	10	0,41	0,33	0,21	0,18
WA-2	10	0,28	0,21	x	x
WA-3	10	0,28	0,22	0,14	x
WA-4	10	0,20	0,13	x	x
WA-5/1	10	0,15	x	x	x
WA-8/1	10	0,18	x	x	x
WA-14/1	10	0,18	x	x	x

SAL-4,5/D60 code 42116		acceptable windage of luminaires and extension arms [m ²] for C _x =1			
		Vref. = 22 m/s	Vref. = 24 m/s	Vref. = 26 m/s	Vref. = 28 m/s
acceptable mass of luminaires and extension arms [kg]		I zone, II location category	I and III zone, II location category to 450 m AMSL	II zone, II location category	III zone, II location category to 755 m AMSL
20		0,37	0,31	0,22	0,2

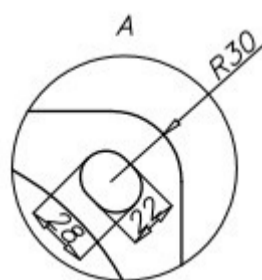
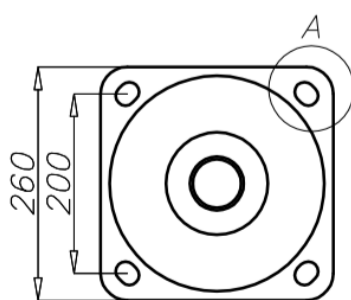

- surface: polished aluminium
- anodizing in 12 colours
- option of powder painting in RAL colours (other colours available on request)
- elastomer protection option in the color of the column to a height of 350 mm (other height on request)
- ROSA standard wiring chamber
- packing: sleeve material