

Aluminium column SAL-80

diameter 146 mm at the base plate



Technical data

Aluminium Column	SAL-80
Product code	42317
Column height H [m]	8
Wall thickness [mm]	4,2
Net weight [kg]	35,2
Volume [m ³]	0,353
Post top column	luminaires with $\varnothing 60$ spigot entry with weight and windage not exceeding data in resistance calculations
Compatible extension arms	according to resistance calculations
Concrete footing / reinforcement basket	B-60 / Z-60
Concrete footing code/reinforcement basket code	311160 / 311206
Hot galvanized nut set /Hot galvanized ripable nut set	4008 / 4009

Resistance calculations

SAL-80 code 42317		acceptable windage of single luminaire [m ²] for Cx=0,7			
		Vref. = 22 m/s	Vref. = 24 m/s	Vref. = 26 m/s	Vref. = 28 m/s
extension arm type	acceptable weight of single luminaire	I zone, II location category	I and III zone, II location category to 450m AMSL	II zone, II location category	III zone, II location category to 755m AMSL
WA-01	10	0,3	0,20	x	x
WA-1	10	0,32	0,22	x	x
WA-2	10	0,22	0,13	x	x
WA-3	10	0,27	0,18	x	x
WA-4	10	0,14	x	x	x
WA-5/1	10	0,19	x	x	x
WA-8/1	10	0,21	x	x	x
WA-11/1	10	0,21	x	x	x
WA-14/1	10	0,22	x	x	x
WA-15/1 P	10	0,24	0,14	x	x
WA-15/1 U	15	0,13	x	x	x
WR-1/1	15	0,29	0,20	x	x
WR-2/1	15	0,22	0,13	x	x
WR-3/1	15	0,22	0,13	x	x
WR-4/1	15	0,29	0,19	x	x
WR-5A/1	15	0,19	x	x	x
WR-6A/1	15	0,25	0,16	x	x
WR-8A/1	15	0,19	x	x	x
WR-13/1	15	0,15	x	x	x
WR-14/1	15	0,16	x	x	x
WR-15/1	15	0,19	x	x	x
WN-1	15	0,25 (Cx=1)	0,18 (Cx=1)	x	x

SAL-80 code 42317		acceptable windage of luminaires and extension arms [m ²] for Cx=1			
		Vref. = 22 m/s	Vref. = 24 m/s	Vref. = 26 m/s	Vref. = 28 m/s
acceptable mass of luminaires and extension arms [kg]		I zone, II location category	I and III zone, II location category to 450m AMSL	II zone, II location category	III zone, II location category to 755m AMSL
30		0,26	0,19	x	x

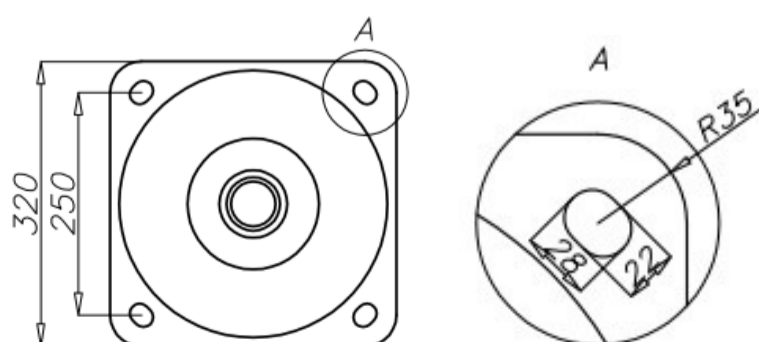
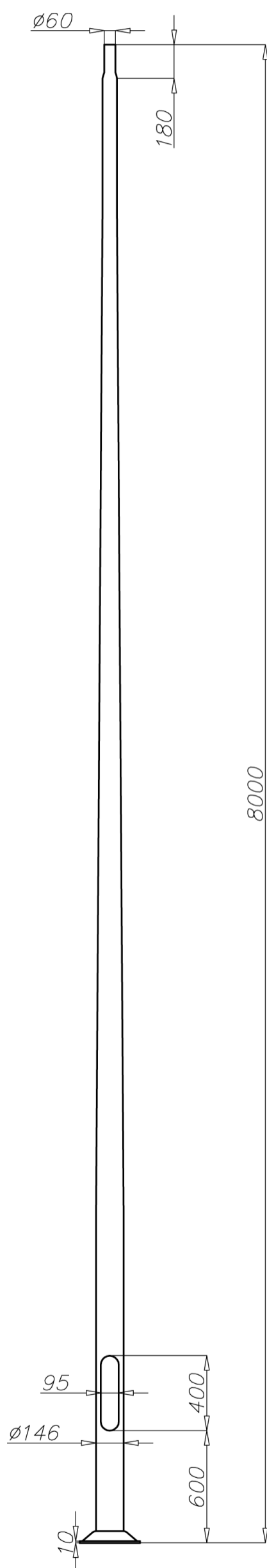

- surface: polished aluminium
- anodizing in 12 colours
- option of powder painting in RAL colours (other colours available on request)
- elastomer protection option in the color of the column to a height of 350 mm (other height on request)
- ROSA standard wiring chamber
- packing: sleeve material