

Aluminium column MAL-15

diameter 225 mm at the base plate



Technical data

Aluminium Column	MAL-15
Product code	42506
Column height H [m]	15
Wall thickness [mm]	5
Net weight [kg]	111,1
Volume [m ³]	0,77
Post top column	luminaires with $\varnothing 100$ spigot entry with weight and windage not exceeding data in resistance calculations
Compatible extension arms	according to resistance calculations
Concrete footing / reinforcement basket	B-80 / Z-80
Concrete footing code/reinforcement basket code	311180 / 311208
Hot galvanized nut set /Hot galvanized ripable nut set	4014

Resistance calculations

MAL-15 code 42506		acceptable windage of single luminaire [m ²] for C _x =1			
		Vref. = 22 m/s	Vref. = 24 m/s	Vref. = 26 m/s	Vref. = 28 m/s
extension arm type	acceptable weight of single luminaire	I zone, II location category	I and III zone, II location category to 450m AMSL	II zone, II location category	III zone, II location category to 755m AMSL
WM-1	15	0,37	0,36	0,24	0,21
WM-2	15	0,19	0,14	x	x
WM-21	15	0,15	0,11	x	x
WM-3	15	0,13	0,10	x	x
WM-4	15	0,11	x	x	x

MAL-15 code 42506		acceptable windage of luminaires and extension arms [m ²] for C _x =1			
		Vref. = 22 m/s	Vref. = 24 m/s	Vref. = 26 m/s	Vref. = 28 m/s
acceptable mass of luminaires and extension arms [kg]		I zone, II location category	I and III zone, II location category to 450m AMSL	II zone, II location category	III zone, II location category to 755m AMSL
40		0,43	0,34	0,24	0,21
90		0,31	0,24	0,16	0,13

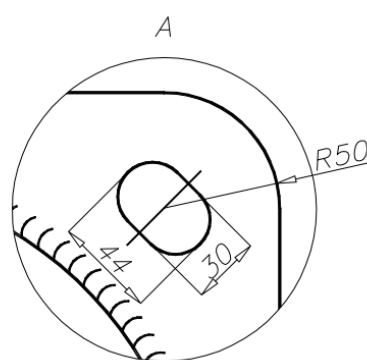
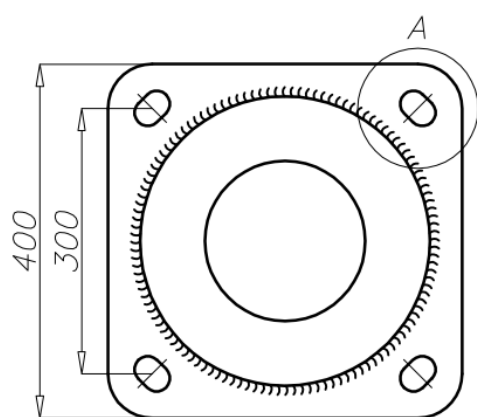
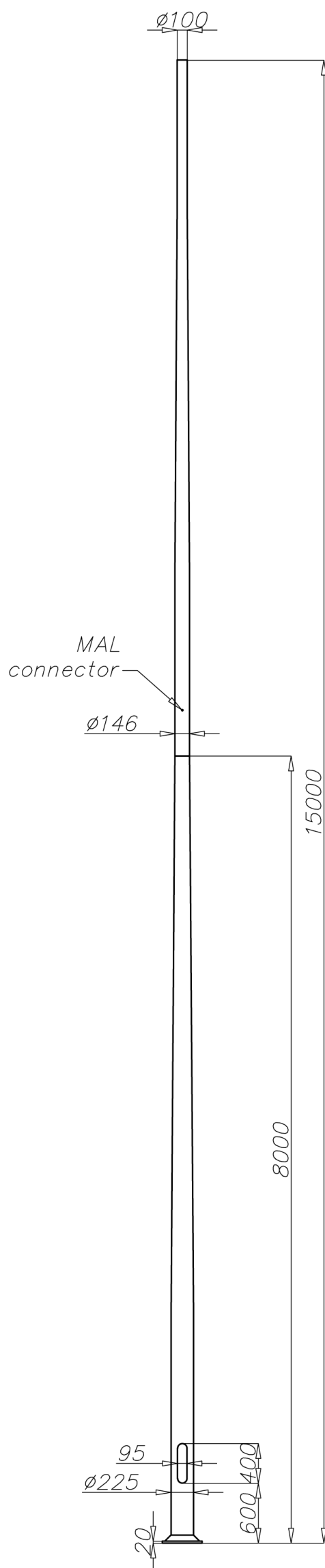

- surface: polished aluminium
- anodizing in 12 colours
- option of powder painting in RAL colours (other colours available on request)
- elastomer protection option in the color of the column to a height of 350 mm (other height on request)
- ROSA standard wiring chamber
- packing: sleeve material