

Aluminium column MAL-12,5 wzm

diameter 225 mm at the base plate



Technical data

Aluminium Column	MAL-12,5 wzm
Product code	42551
Column height H [m]	12,5
Wall thickness [mm]	5
Net weight [kg]	101,2
Volume [m ³]	0,64
Post top column	luminaires with $\varnothing 100$ spigot entry with weight and windage not exceeding data in resistance calculations
Compatible extension arms	according to resistance calculations
Concrete footing / reinforcement basket	B-80 / Z-80
Concrete footing code/reinforcement basket code	311180 / 311208
Hot galvanized nut set /Hot galvanized ripable nut set	4014

Resistance calculations

MAL-12,5 wzm code 42551		acceptable windage of single luminaire [m ²] for Cx=1			
		Vref. = 22 m/s	Vref. = 24 m/s	Vref. = 26 m/s	Vref. = 28 m/s
extension arm type	acceptable weight of single luminaire	I zone, II location category	I and III zone, II location category to 450m AMSL	II zone, II location category	III zone, II location category to 755m AMSL
WRK-3	15	0,49 (Cx=0,7)	0,39 (Cx=0,7)	0,27 (Cx=0,7)	0,24 (Cx=0,7)
WRK-4	15	0,44 (Cx=0,7)	0,35 (Cx=0,7)	x	0,2 (Cx=0,7)
WRK-5	15	0,34 (Cx=0,7)	0,26 (Cx=0,7)	0,15 (Cx=0,7)	0,11 (Cx=0,7)
WRK-6	15	0,25 (Cx=0,7)	0,17 (Cx=0,7)	x	x
WM-1	15	0,37	1,12	0,87	0,79
WM-2	15	0,60	0,51	0,39	0,36
WM-21	15	0,56	0,47	0,36	0,32
WM-3	15	0,45	0,38	0,29	0,26
WM-4	15	0,42	0,36	0,27	0,24
WM-42	15	0,36	0,29	0,21	0,18
WM-5	15	0,37	0,31	0,22	0,20
WM-6	15	0,34	0,28	0,20	0,17

MAL-12,5 wzm code 42551		acceptable windage of luminaires and extension arms [m ²] for Cx=1			
		Vref. = 22 m/s	Vref. = 24 m/s	Vref. = 26 m/s	Vref. = 28 m/s
acceptable mass of luminaires and extension arms [kg]		I zone, II location category	I and III zone, II location category to 450m AMSL	II zone, II location category	III zone, II location category to 755m AMSL
100		1,07	0,92	0,71	0,65

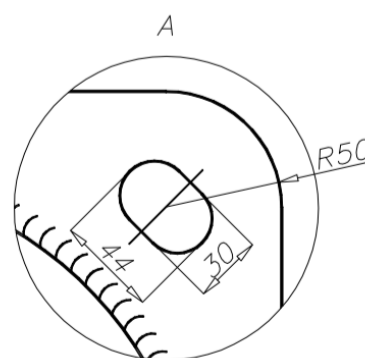
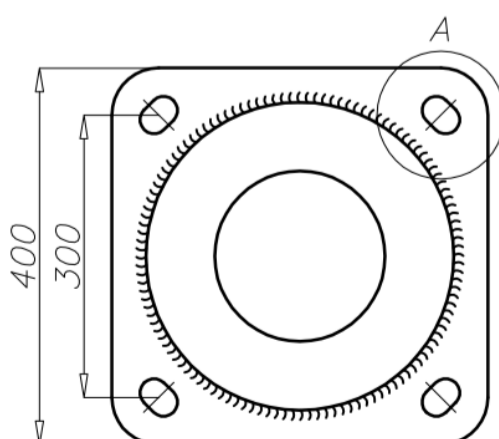
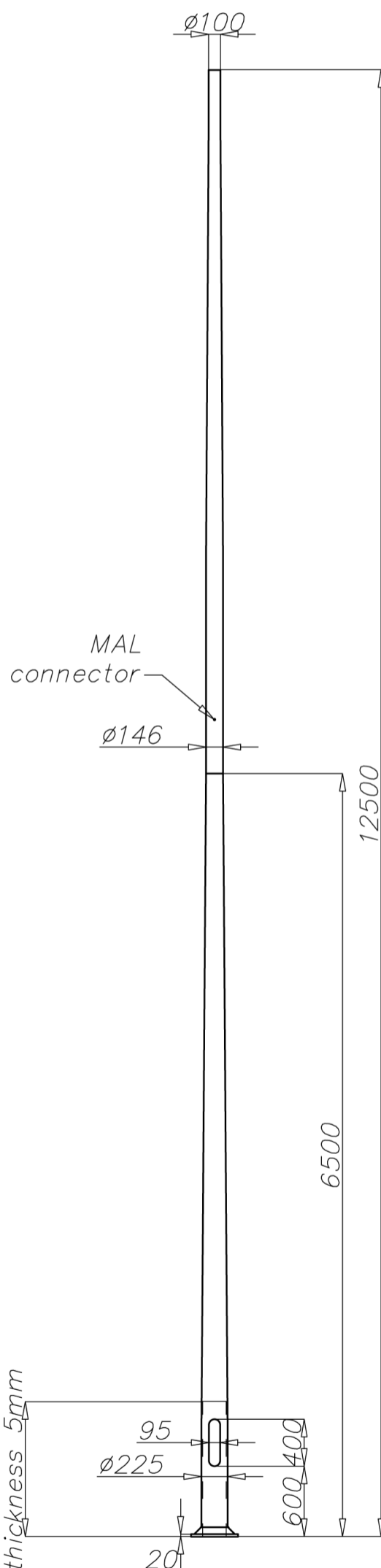

- surface: polished aluminium
- anodizing in 12 colours
- option of powder painting in RAL colours (other colours available on request)
- elastomer protection option in the color of the column to a height of 350 mm (other height on request)
- ROSA standard wiring chamber
- packing: sleeve material