

Aluminium column SAL-100K

diameter 178 mm at the base plate

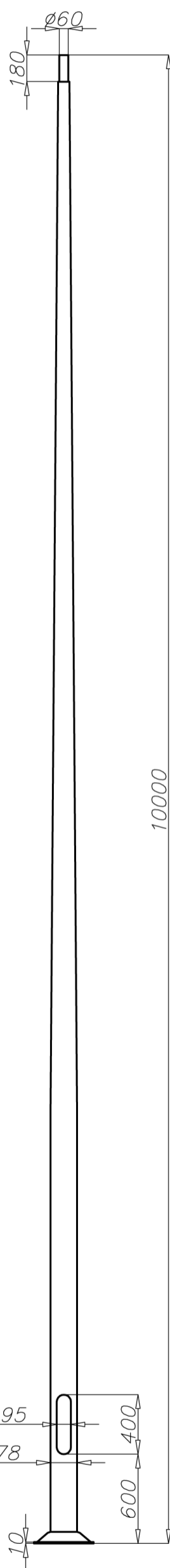

Technical data

Aluminium Column	SAL-100K
Product code	42634
Column height H [m]	10
Wall thickness [mm]	3,5
Net weight [kg]	47,5
Volume [m ³]	0,654
Post top column	luminaires with $\varnothing 60$ spigot entry with weight and windage not exceeding data in resistance calculations
Compatible extension arms	according to resistance calculations
Concrete footing / reinforcement basket	B-71, B-70 / Z-71, Z-70
Concrete footing code/reinforcement basket code	311171, 311170/311271, 311207
Hot galvanized nut set /Hot galvanized ripable nut set	4012 / 4013

Resistance calculations

SAL-100K code 42634		acceptable windage of single luminaire [m ²] for C _x =0,7			
		Vref. = 22 m/s	Vref. = 24 m/s	Vref. = 26 m/s	Vref. = 28 m/s
extension arm type	acceptable weight of single luminaire	I zone, II location category	I and III zone, II location category to 450m AMSL	II zone, II location category	III zone, II location category to 755m AMSL
WR-1/1	15	0,25	0,17	x	x
WR-2/1	15	0,15	x	x	x
WR-3/1	15	0,14	x	x	x
WR-4/1	15	0,23	0,15	x	x
WR-5A/1	15	0,14	x	x	x
WR-6A/1	15	0,23	0,16	x	x
WR-8A/1	15	0,15	x	x	x
WR-13/1	15	0,10	x	x	x
WR-14/1	15	0,11	x	x	x
WR-15/1	15	0,12	x	x	x
WRP1/1,0/0,7/5	15	0,13	x	x	x
WN-1	15	0,23	0,17	x	x

SAL-100K code 42634		acceptable windage of luminaires and extension arms [m ²] for C _x =1			
		Vref. = 22 m/s	Vref. = 24 m/s	Vref. = 26 m/s	Vref. = 28 m/s
acceptable mass of luminaires and extension arms [kg]		I zone, II location category	I and III zone, II location category to 450m AMSL	II zone, II location category	III zone, II location category to 755m AMSL
30		0,23	0,18	0,11	x

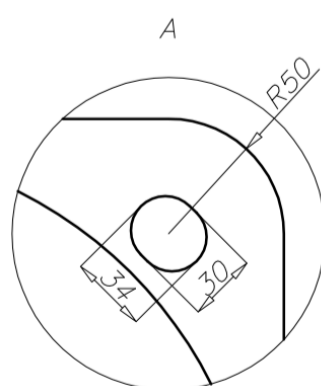
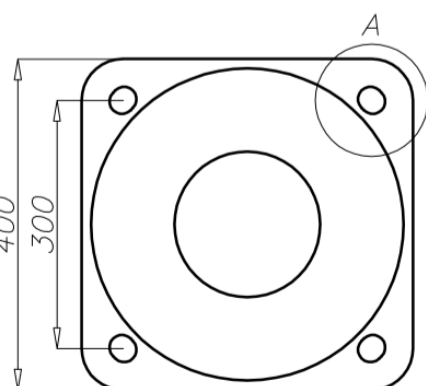

- surface: polished aluminium
- anodizing in 12 colours
- option of powder painting in RAL colours (other colours available on request)
- elastomer protection option in the color of the column to a height of 350 mm (other height on request)
- ROSA standard wiring chamber
- packing: sleeve material