

# Aluminium column SAL-90M

diameter 180 mm at the base plate

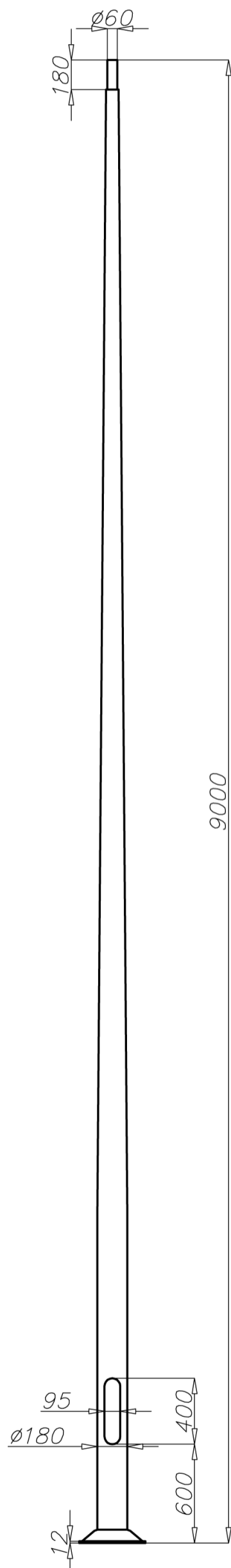

## Technical data

Aluminium Column	SAL-90M
Product code	42757
Column height H [m]	9
Wall thickness [mm]	4,3
Net weight [kg]	49,3
Volume [m <sup>3</sup> ]	0,589
Post top column	luminaires with $\varnothing 60$ spigot entry with weight and windage not exceeding data in resistance calculations
Compatible extension arms	according to resistance calculations
Concrete footing / reinforcement basket	B-71, B-70 / Z-71, Z-70
Concrete footing code/reinforcement basket code	311171, 311170/311271, 311207
Hot galvanized nut set /Hot galvanized ripable nut set	4012 / 4013

## Resistance calculations

SAL-90M code 42757		acceptable windage of single luminaire [m <sup>2</sup> ] for $C_x=0,7$			
		Vref. = 22 m/s	Vref. = 24 m/s	Vref. = 26 m/s	Vref. = 28 m/s
extension arm type	acceptable weight of single luminaire	I zone, II location category	I and III zone, II location category to 450m AMSL	II zone, II location category	III zone, II location category to 755m AMSL
WR-1/1	15	0,83	0,69	0,50	0,45
WR-1/2	15	0,38	0,31	0,21	0,19
WR-2/1	15	0,66	0,53	0,37	0,33
WR-2/2	15	0,32	0,24	0,15	0,12
WR-2/3	15	0,23	0,17	0,10	x
WR-3/1	15	0,63	0,51	0,35	0,31
WR-3/2	15	0,31	0,24	0,15	0,12
WR-3/3	15	0,22	0,17	0,10	x
WR-4/1	15	0,79	0,65	0,47	0,42
WR-4/2	15	0,39	0,31	0,21	0,19
WR-5A/1	15	0,66	0,53	0,37	0,32
WR-5A/2	15	0,30	0,23	0,15	0,12
WR-6A/1	15	0,84	0,69	0,50	0,44
WR-8/1	15	0,48	0,37	0,23	0,19
WR-8A/1	15	0,67	0,54	0,38	0,33
WR-9/1	15	0,46	0,35	0,21	0,17
WR-9/2	15	0,15	x	x	x
WR-12/1	15	0,50	0,39	0,24	0,20
WR-13/1	15	0,64	0,51	0,34	0,29
WR-13/2	15	0,28	0,20	0,11	x
WR-13/3	15	0,20	0,14	x	x
WR-14/1	15	0,57	0,46	0,31	0,27
WR-15/1	15	0,64	0,52	0,35	0,30
WR-15/2	15	0,32	0,24	0,14	0,11
WR-15/3	15	0,23	0,17	x	x
WR-17/1	10	0,36	0,26	0,13	x
WR-17/2	8	0,11	x	x	x

# Aluminium column SAL-90M

diameter 180 mm at the base plate

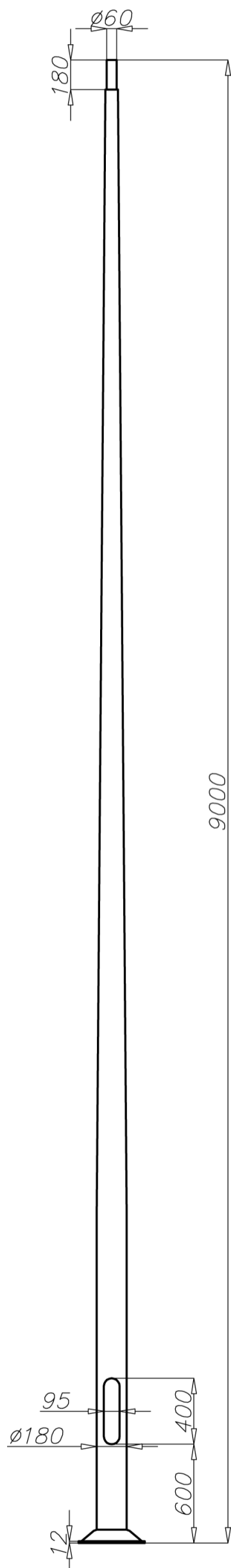

## Resistance calculations

SAL-90M code 42757		acceptable windage of single luminaire [m <sup>2</sup> ] for C <sub>x</sub> =0,7			
		Vref. = 22 m/s	Vref. = 24 m/s	Vref. = 26 m/s	Vref. = 28 m/s
extension arm type	acceptable weight of single luminaire	I zone, II location category	I and III zone, II location category to 450m AMSL	II zone, II location category	III zone, II location category to 755m AMSL
WR-18	15	0,41	0,31	0,18	0,14
WR-18A	15	0,32	0,22	0,10	x
WR-18B	15	0,24	0,16	x	x
WR-31	15	0,34	0,23	x	x
WR-61	15	0,39	0,29	0,16	0,12
WRP1/1,0/0,7/5	15	0,62	0,49	0,34	0,29
WRP1/1,0/1,2/5	15	0,51	0,40	0,25	0,21
WRP1/1,5/0,7/5	15	0,51	0,40	0,26	0,22
WRP1/1,5/1,2/5	15	0,41	0,31	0,18	0,14
WRP2/1,0/0,7/5	15	0,31	0,24	0,14	0,11
WRP2/1,0/1,2/5	15	0,24	0,17	x	x
WRP2/1,5/0,7/5	15	0,26	0,18	x	x
WRP2/1,5/1,2/5	15	0,19	0,12	x	x
WRP3/1,0/0,7/5	15	0,24	0,18	0,11	x
WRP3/1,0/1,2/5	15	0,18	0,13	x	x
WRP3/1,5/0,7/5	15	0,21	0,15	x	x
WRP3/1,5/1,2/5	15	0,15	0,10	x	x
WN-1	15	0,7 (C <sub>x</sub> =1)	0,58 (C <sub>x</sub> =1)	0,43 (C <sub>x</sub> =1)	0,39 (C <sub>x</sub> =1)
WN-2	15	0,32 (C <sub>x</sub> =1)	0,26 (C <sub>x</sub> =1)	0,19 (C <sub>x</sub> =1)	0,17 (C <sub>x</sub> =1)
WN-21	15	0,3 (C <sub>x</sub> =1)	0,24 (C <sub>x</sub> =1)	0,17 (C <sub>x</sub> =1)	0,15 (C <sub>x</sub> =1)
WN-3	15	0,22 (C <sub>x</sub> =1)	0,18 (C <sub>x</sub> =1)	0,12 (C <sub>x</sub> =1)	0,11 (C <sub>x</sub> =1)
WN-4	12	0,21 (C <sub>x</sub> =1)	0,17 (C <sub>x</sub> =1)	0,12 (C <sub>x</sub> =1)	0,1 (C <sub>x</sub> =1)
WN-42	12	0,21 (C <sub>x</sub> =1)	0,17 (C <sub>x</sub> =1)	0,12 (C <sub>x</sub> =1)	0,1 (C <sub>x</sub> =1)

SAL-90M code 42757		acceptable windage of luminaires and extension arms [m <sup>2</sup> ] for C <sub>x</sub> =1			
		Vref. = 22 m/s	Vref. = 24 m/s	Vref. = 26 m/s	Vref. = 28 m/s
acceptable mass of luminaires and extension arms [kg]		I zone, II location category	I and III zone, II location category to 450m AMSL	II zone, II location category	III zone, II location category to 755m AMSL
50		0,65	0,54	0,40	0,36

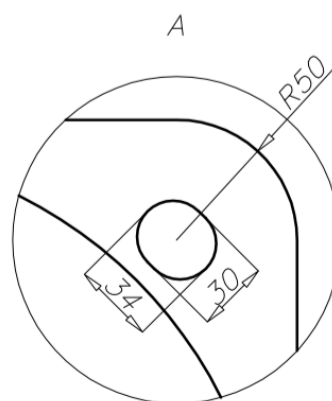
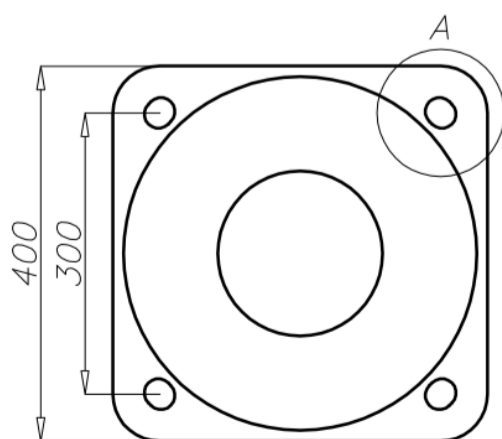

- surface: polished aluminium
- anodizing in 12 colours
- option of powder painting in RAL colours (other colours available on request)
- elastomer protection option in the color of the column to a height of 350 mm (other height on request)
- ROSA standard wiring chamber
- packing: sleeve material