

# Aluminium extension arm WTM-15/1U

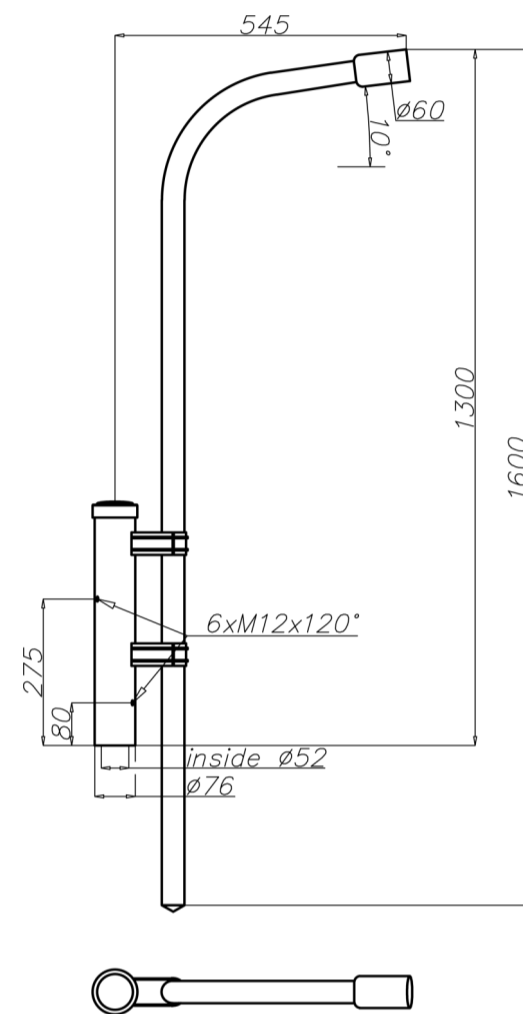

## Technical data

Extension arm	WTM-15/1 U
Product code	476150/C35
Application	poles type SM and SP with spigot ending "E"
Arm quantity	1
Net weight [kg]	4,4
Volume [m <sup>3</sup> ]	0,056
Assembling diameter of luminaire Ø [mm]	Ø 60
Compatible luminaires	street luminaires

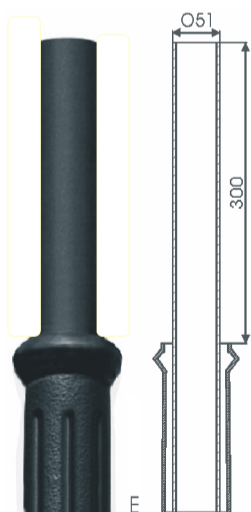

- standard anodized in black
- possibility of anodizing in other colours
- option of powder painting in RAL colours (other colours available on request)
- packing: stretch foil