

# Aluminium extension arm WTM-16/2

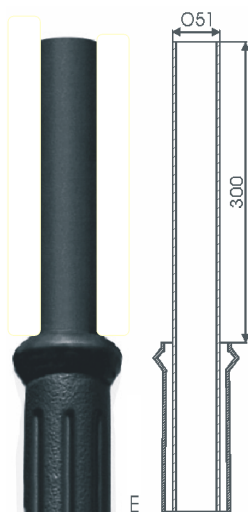
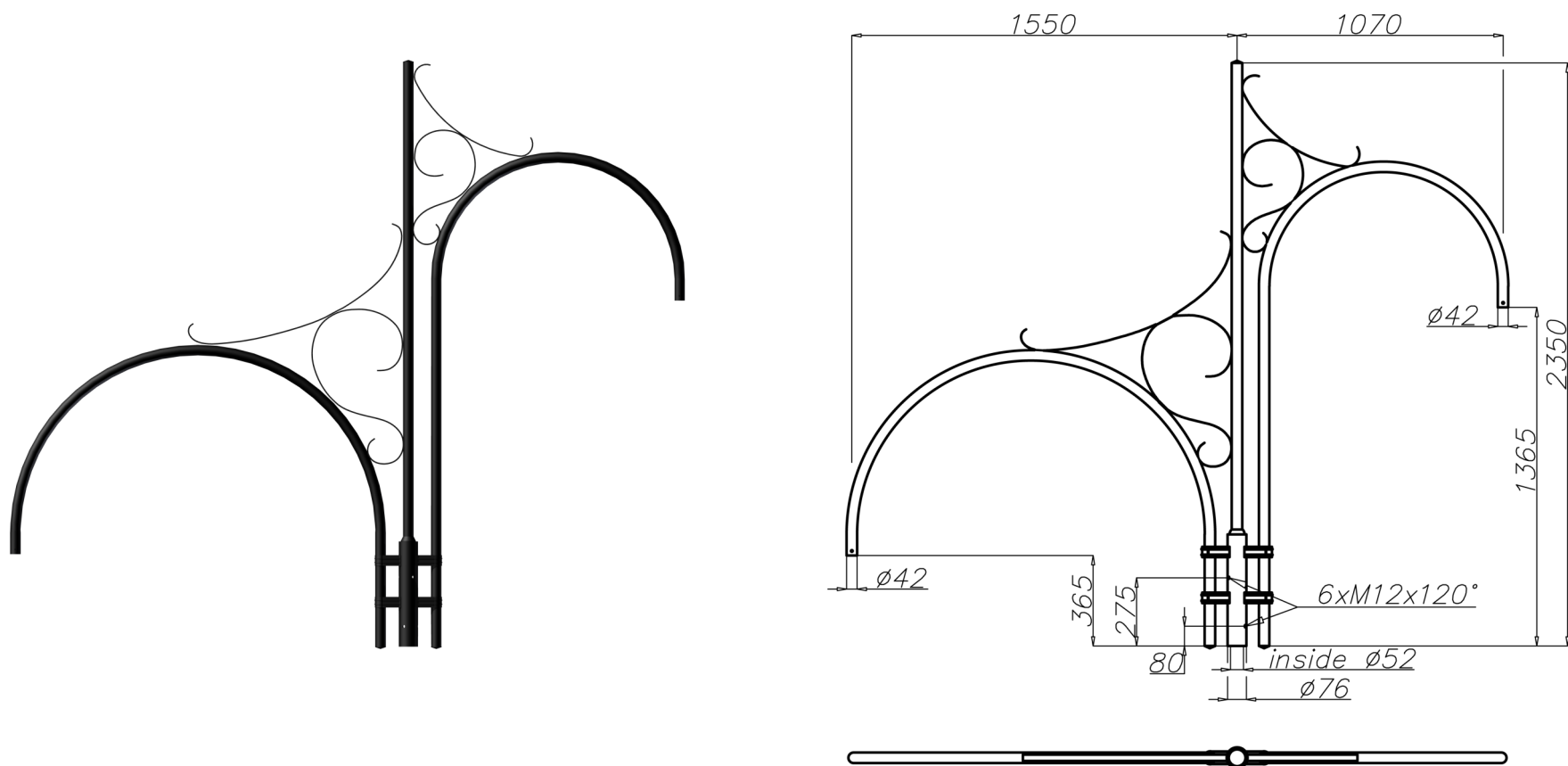

## Technical data

Extension arm	WTM-16/2
Product code	476162/C35
Application	poles type SM and SP with spigot ending "E"
Arm quantity	2
Net weight [kg]	12,3
Volume [m <sup>3</sup> ]	0,30
Assembling diameter of luminaire $\varnothing$ [mm]	$\varnothing$ 42
Compatible luminaires	OW, OW-2, OPA

- standard anodized in black
- possibility of anodizing in other colours
- option of powder painting in RAL colours (other colours available on request)
- packing: stretch foil